

Full length article

A compact grating-stabilized diode laser system for atomic physics

L. Ricci, M. Weidemüller, T. Esslinger, A. Hemmerich, C. Zimmermann,
V. Vuletic, W. König, T.W. Hänsch

*Sektion Physik, Universität München, Schellingstraße 4/III, D-80799 Munich, Germany
and Max-Planck-Institut für Quantenoptik, D-85748 Garching, Germany*

Received 21 December 1994

Abstract

We describe a compact, economic and versatile diode laser system based on commercial laser diodes, optically stabilized by means of feedback from a diffraction grating. We offer detailed information which should enable the reader to copy our set-up which uses only easily machined mechanical parts. Our system offers single-mode operation with a linewidth of a few 100 kHz, continuous scans over 25 GHz, high chirp rates (up to 9 GHz/ms) and FM-modulation up to the GHz range. We discuss radio-frequency phase-locking of two independent lasers systems, allowing well controlled fast frequency switching which overcomes the limitations imposed by acousto-optic modulators.

1. Introduction

Since their first use in atomic physics in the early 80's [1], diode lasers have become an important part of many modern experiments. This is primarily due to the high reliability and the low price of these devices which facilitate experiments involving a number of lasers operating at different frequencies. The imperfect spectral features of free-running laser diodes (mode-hopping and large linewidth) can be dramatically improved by exploiting their sensitivity to optical feedback [2]. During the past decade several stabilization arrangements have been presented, either using coupling to an external, high- Q cavity [3] or to a diffraction grating [4,5]. In the first case, a fraction of the output beam is coupled into a high- Q Fabry-Pérot resonator and redirected back into the diode laser. While geometries of this kind can provide radiation with a linewidth below 10 kHz [3], their relatively high level of technical complexity is a drawback for many applications. For example, to select a specific longitudinal

mode of the diode laser cavity, additional weak feedback is generally required, e.g. from a thin (100 μm) glass plate mounted closely (about 100 μm) to the diode's front facet [6]. In many instances, this is only possible by removing the sealed diode case, a delicate procedure which may also accelerate the aging of the diode. To achieve stable, long term operation, electronic feedback is necessary to control the optical path length between the external cavity and the laser diode.

By contrast, in view of these difficulties, the stabilization of laser diodes achieved by means of feedback from a diffraction grating is much simpler to realize and still provides a linewidth reduction to the 100 kHz level which is sufficient for many experiments. In this arrangement, the light diffracted from a grating is coupled back into the diode, so that the grating and the diode's rear facet form an external resonator. The diode chip, with its reflecting facets, acts like an intracavity etalon and the external diffraction grating selects a single-mode of the chip. The use of a grating results in a linewidth reduction of two orders of magnitude and it

also allows the selection of any desired wavelength; all this is achieved with the same element and without further electronic feedback. The simplicity of this stabilization arrangement has led a number of research groups to design laser systems utilizing the technique. Their success in many experiments in atomic physics has stimulated an increasing interest in this scheme. Although a detailed and comprehensive description of a grating stabilized laser diode system is already available [4,5], this article presents an alternative, very compact and economic mechanical design. Our setup can easily be manufactured and provides high passive stability resulting in low frequency drift rates. The system has so far been copied by several research groups due to its remarkable performance features. As examples we will present the frequency modulation characteristics of the diode laser system and optical phase-locking of two independent systems. Our specific design is especially suited for both applications.

Since the linewidth of a grating-stabilized diode laser decreases with the square of the external cavity length [7], it may appear desirable to use a long external resonator, by setting the grating rather far from the diode. However, if the axial mode spacing of the external resonator is smaller than the characteristic frequency of the relaxation oscillations (typically a few GHz), we have found that reliable, single-mode operation can be only achieved by providing the laser diodes with special antireflection coatings on the output facets. Otherwise severe instabilities are observed, e.g. multi-mode operation or pulsing. For this reason, we have chosen a very short external cavity (about 15 mm), which achieves single-mode operation with almost any commercial laser diode and without the need for the delicate procedure of opening the diode laser housing and applying additional coatings to the laser chip. We still achieve free-running laser linewidths of typically a few hundred kHz which are more than sufficient for many experiments.

The laser frequency critically depends on the length of the external cavity. The entire assembly should therefore be designed with a mechanical stability similar to that of a good Fabry–Pérot interferometer. The use of commercial mechanical components, as for example adjustable mirror holders, generally involves severe sacrifices in acoustic rigidity and thermal stability. We have therefore chosen easy-to-machine small metal blocks of flex-mount design which provide sat-

isfactory stability. The compact design makes it feasible to stabilize the temperature of the entire laser system by mounting it on a small Peltier element. In this way, thermal drifts of the cavity length are effectively reduced without any need to resort to special, hard-to-machine materials with low thermal expansion.

Our arrangement has been used with InGaAlP laser diodes operating at 655, 670 and 690 nm and with GaAlAs laser diodes operating both at 780 and 850 nm. The compact mechanical design permits high passive frequency stability, large tuning ranges and high chirp-rates. The relatively low spectral selectivity of the optical feedback allows efficient frequency modulation of the emitted radiation in the radio-frequency and microwave region. These characteristics make this stabilization geometry particularly suitable for a wide range of applications in atomic physics. We have, for example, used these diode lasers for cooling and trapping of alkalis [8], for the observation of ultra-narrow resonances involving dark states, for the preparation of optical lattices [9], in the realization of atomic mirrors [10] and in the construction of frequency dividers [11]. Owing to their reliability, our laser system is currently utilized in a frequency chain for direct measurements of optical frequencies [12].

This paper aims to offer a practical description of our diode laser system which should enable the reader to copy it. Theoretical analysis of the different kinds of optical feedback arrangements can be found in published literature, such as in the articles quoted in references [13]. We will first provide a description of the set-up and of the alignment procedure, then discuss the tuning, chirping and frequency modulation characteristics of the system and finally, we will describe a high-performance phase-locking arrangement involving two grating-stabilized laser diodes. Though very simple, this arrangement makes it possible to change the frequency difference between the two lasers without intensity modulation on the 100 MHz scale to within 100 μ s, maintaining the phase difference well defined within a fraction of 2π . Since the frequency difference is determined by the voltage-tuned oscillator (VTO), which serves as the local oscillator, a broad range of frequencies can be covered by simply exchanging the VTO. Thus, this phase-locking technique offers major advantages in applications where scientists have so far used acoustooptic modulators.

2. Mechanical design, alignment

Let us start by summarizing some of the features typical for free-running index guided, single-mode, laser diodes. The gain profile of such laser diodes typically has a width of 10 nm. The emission wavelength is determined by the competition between the longitudinal modes of the laser cavity, which are typically separated by 100–200 GHz. The laser operates at the mode which experiences the maximum gain. Temperature variations cause a change of the cavity length (and thus a change of the resonance frequencies of the longitudinal modes) and at the same time a frequency shift of the gain profile. Consequently, the emission wavelength can be tuned with the temperature. However, in the process of tuning, the gain of the modes varies such that at some point the laser emission frequency jumps from one mode to another (mode-hopping), resulting in a number of inaccessible frequency domains. The width of the accessible frequency domains is typically a fraction of the free spectral range of the laser cavity, i.e. several tens of GHz, while the separation between two adjacent domains is a multiple (occasionally larger than 1) of the free spectral range. A second method which can be employed to tune the emission wavelength is to vary the injection current. This leads to a corresponding temperature change and also a change of the carrier density and thus of the refractive index of the semiconductor material. Injection current tuning also suffers from mode hopping. While temperature tuning can cover a frequency range of the order of several tens of nm at a typical rate of 0.3 nm/K, injection current tuning typically covers a range of several tens of GHz only at a typical rate of 4 GHz/mA. However it should be noted that injection current can be varied much more quickly than the corresponding temperature change. If a low noise current supply is used (i.e. injection current noise $< 1 \mu\text{A}$ integrated over 100 kHz), the linewidth of a free-running, single-mode, laser diode is typically of the order of some tens of MHz.

A simple ruled or holographic diffraction grating can be used to build a laser system which can be tuned to any desired wavelength within the gain profile of the semiconductor material and at the same time offers a laser linewidth at the 100 kHz level. As mentioned above, this can be accomplished by aligning the first diffraction order back into the laser diode, so the grating

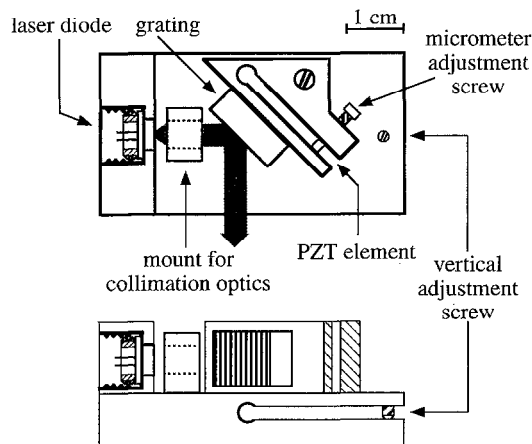

Fig. 1. Schematics of the mechanical setup of the grating-stabilized diode laser system.

and the output facet of the diode form an external cavity which is optically coupled to the laser diode cavity. The external resonator may be modeled as a frequency dependent mirror with a complex reflectivity. The grating selects one of the modes of the external cavity. The emission frequency can be continuously tuned by about half of the free spectral range of the external resonator, i.e. about 4 GHz, by varying the resonator length, before the laser jumps to an other longitudinal mode. If the grating is synchronously tilted by an appropriate amount, extended scanning is possible up to about half a free spectral range of the diode laser cavity (i.e. several tens of GHz).

Fig. 1 shows a sketch of our diode laser system. The mounting system consists essentially of three parts: an L-shaped metal block, holding the laser diode, a mount for the collimation optics and an adjustable mount for the diffraction grating. All metallic parts are made of ‘neusilber’, a compound comprised of 62% copper, 18% nickel, and 20% zinc. ‘Neusilber’ combines high heat conductivity with reasonable elasticity and can be machined as easily as aluminium. Among the types of laser diodes we have used are: Toshiba TOLD9421 at 655 nm (specified output power 5 mW), Toshiba TOLD9215 at 670 nm (specified output power 10 mW), Sharp LTO24 at 780 nm (specified output power 30 mW), Hitachi HL7851G at 780 nm (specified output power 50 mW), Sharp LTO15 at 840 nm (specified output power 30 mW) and STC-LT50A-03U at 850 nm (specified output power 100 mW). These kinds of

laser diodes are generally available with emission wavelengths spread in ranges varying over 5 nm for the 670 nm diodes and over 15 nm for the infrared diodes. We recommend the purchase of diodes providing a free-running wavelength slightly (3–5 nm) higher than the desired frequency and to use temperature tuning (cooling) to coarsely approach the desired emission frequency. We have observed that the higher the free-running wavelength, the longer the life time and the reliability of the laser diode, particularly in case of the red diodes. However, temperature tuning towards smaller wavelengths by more than 5 nm requires cooling to such low temperatures that moisture may condensate such that the system can no longer be operated open to the atmosphere.

In the following section, we describe the steps for assembling and adjusting the laser system in the order in which they should be carried out. The laser diode is fixed to the main L-shaped block in a mounting hole by means of a threaded ring. Some heat conducting grease provides sufficient thermal coupling between the laser diode and the main block. (The diode case is not removed and no antireflection coating is applied on the output facet). The linear polarization of the output light (which is parallel to the minor axis of the elliptical beam pattern) is aligned vertically. The divergence of the laser beam is corrected through a collimating lens system (Melles-Griot 06GLC009). The position and orientation of the collimator must be carefully adjusted in order to optimize the final laser performance. For this purpose the lens mount assembly is positioned with the help of a *x-y-z* precision translation stage. Lateral (vertical and horizontal) adjustment is needed in order to align the optical axis of the lens with that of the laser beam which then results in a perfectly elliptical beam shape in the far field. The collimating lens should not be tilted with respect to the laser axis in order to minimize additional astigmatism. The distance between the lens and the laser diode is adjusted so that the output beam is well collimated. This can be achieved by minimizing the laser beam diameter at a distance of several meters away from the diode. Once the optimal position is achieved, the lens holder is cemented to the main block. We have found dentists' compounds for the filling of dental cavities to work well (for example Heliobond, Vivadent Dental): these cements are easily shaped until cured by illumination with blue light

(Heliolux II, Vivadent Dental) and their volume does not change much during the hardening process.

The emission wavelength is tuned approximately (within 1 nm) to the desired wavelength by adjusting the temperature of the main block. Thus, the maximum power output and the optimal performance of the system are ensured. A sensor (Analog Devices AD590), fixed in the main block close to the laser diode, is used to measure the temperature. The main block is placed on a Peltier element mounted on an aluminum base plate, acting as thermal sink. The temperature of the whole set-up should be stabilized with an electronic servo-loop to within a few mK.

The grating is mounted in the Littrow configuration in order to couple the first diffraction order back into the laser diode. The distance between laser diode and grating is about 15 mm. A fraction of the beam incident on the grating is reflected out of the external resonator (zeroth order) and constitutes the output of the stabilized laser. The number of lines per millimeter is chosen so that the angle between incident beam and zeroth order is close to 90°. The gratings (Jenoptik) used in our set-ups have 2100 lines/mm for $\lambda = 670$ nm and 1800 lines/mm for $\lambda = 780$ nm and $\lambda = 850$ nm. About 15–30% of the incident power is coupled into the first diffraction order. Orienting the grating lines parallel to the light polarization provides the optimum wavelength selectivity. The grating is cemented to an adjustable lever arm which is simply obtained by cutting a slit into the grating mount (see Fig. 1). The fine adjustment of the horizontal angle between the grating and the incident laser beam is achieved through a micrometer screw which slightly tilts the lever arm. A piezoelectric transducer (PZT) is placed between the lever and the micrometer screw.

The grating mount is bolted to the main block after rough orientation such that two distinct, nearly parallel light beams emerge from the grating. The brighter beam is the zeroth order reflection of the beam incident on the grating. The second weaker beam results from the first diffraction order, back-reflected by the diode. To align the grating we use an iterative procedure. We begin by setting the injection current such that the diode laser operates slightly below threshold. By means of both the adjustment screws, the two fluorescence beams emerging from the grating are brought together until they roughly overlap. This should yield a sudden increase of the brightness of the emission resulting from

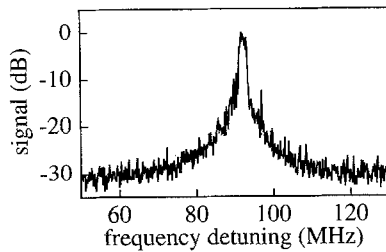

Fig. 2. Beat signal between two independent laser systems at 670 nm.

the fact that laser action has started. The injection current is then reduced until the lasing action disappears and the alignment is repeated. A sufficiently good alignment is characterized by a decrease of the threshold current by about 10–15% as compared to the threshold current of the free-running diode.

The whole set-up is protected by a Plexiglas cover in order to improve its thermal isolation. In this way, we have limited the frequency drift to less than 10 MHz over a few minutes and below 50 MHz over a few hours. Once aligned and stabilized, a laser emits at the same frequency within 100 MHz over weeks, without the necessity of realignment. When the grating has been properly adjusted, the emission linewidth is limited to about 1 MHz by low frequency fluctuations of the optical path length of the external cavity due to mechanical and acoustic noise. Fig. 2 shows a beat note of two independent, grating stabilized laser diodes at 670 nm. The linewidth at -3 dB below maximum is less than 2 MHz, corresponding to a spectral linewidth of about 1 MHz for each laser. With improved acoustic isolation, linewidths of 300 kHz are possible [14]. Alternatively, the output frequency can be locked to an atomic transition by means of low-bandwidth servo-electronics to obtain a stable emission with a linewidth of a few hundred kHz.

3. Frequency tuning and modulation

Coarse adjustment of the wavelength is achieved by horizontally tilting the grating with the micrometer screw. Continuous frequency scans (over 6 GHz) are possible by means of the grating PZT. A length change of the PZT synchronously varies the cavity length and the grating angle. The maximum scan width is limited by the fact that the ratio between longitudinal and angle

adjustment of the grating is not optimal in our design [15] as this is aiming at a compact set-up. Improved scanning characteristics are easily achieved by synchronous variation of the injection current. In this way the emission frequency can be tuned over several tens of GHz without any mode jumps. As an example, Fig. 3 shows a sub-Doppler spectrum of the transitions D1 and D2 of both isotopes of lithium (${}^6\text{Li}$ and ${}^7\text{Li}$) at 670 nm, recorded with a single scan. The signal was obtained by the absorption spectroscopy of a lithium atomic beam. For lithium, both the 2P state fine structure and the isotropic shift (between ${}^6\text{Li}$ and ${}^7\text{Li}$) are equal to about 10 GHz. The total spectrum of the 1S–2P transition is therefore spread over an interval of 21 GHz. The scan width of more than 24 GHz in Fig. 3

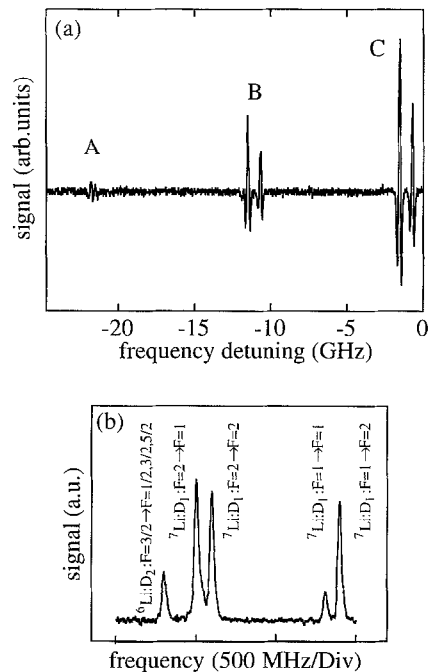

Fig. 3. Absorption spectrum of a lithium beam. The upper spectrum (a) shows a 24 GHz scan of the laser frequency. Due to the increase of the injection current, the laser intensity changes approximately by a factor of two during the scan. In order to eliminate this effect we have observed the second derivative of the absorption spectrum. The laser frequency is slightly modulated at 1 kHz and the second-harmonic of the modulation frequency is detected in the light transmitted through the lithium beam by means of a lock-in amplifier. The lines marked with A and C correspond to the D1 transitions of ${}^6\text{Li}$ and D2 transitions of ${}^7\text{Li}$ respectively. The lower scan (b) shows the line group B magnified.

was only limited by the PZT controlling the grating position.

Note that a variation ΔL of the optical path L of the external cavity yields a relative frequency detuning given by $\Delta\nu/\nu \cong -\Delta L/L$. The detuning $\Delta\nu$ is thus inversely proportional to L and thus a short external cavity allows particularly large frequency scans and at the same time large scanning rates. High scanning rates can be important in atomic physics experiments, e.g. for chirp-cooling of an atomic beam, particularly in case of light atoms [16,17]. Using a laser diode at 670 nm for cooling a lithium beam we have achieved a maximum chirp-rate of about 9 GHz/ms.

The emission frequency of laser diodes can be easily modulated up to the GHz range by modulating the injection current. Frequency modulation has various applications, e.g. in the Pound-Drever-Hall scheme for frequency stabilization [18] or in frequency modulation spectroscopy [19]. Optical frequency stabilization schemes involving external, high- Q resonators [20] strongly reduce the optical response to an injection current modulation. Our grating-stabilized diode laser system can be efficiently frequency modulated up to a few GHz with relatively small RF power (in the mW range) due to the low finesse of its external resonator. Fig. 4 shows spectra of our laser system output modulated at 20 MHz (a) and 500 MHz (b). The current modulation is carried out by capacitively coupling an RF-signal to the current bias line. In order to prevent the reflection of RF power back into the source, appropriate impedance matching should be established. For frequencies higher than a couple of hundred MHz the RF line should be built in a waveguide architecture. In Fig. 4a the modulation index is larger than 1 so that the carrier is almost suppressed and most of the power is transferred to the sidebands. The dependence of the emission power on the injection current yields an additional amplitude modulation, which is responsible for the difference in the intensities of the low-frequency and the high-frequency sideband.

For many applications in atomic physics, laser sources are needed whose frequency difference can be kept constant to a high precision. Typically, two laser frequencies are required which differ by an amount equal to the ground state hyperfine structure of some atom. For this purpose, electro-optic modulators or distinct, synchronized lasers are usually employed. However, the generation of sidebands by FM modulation

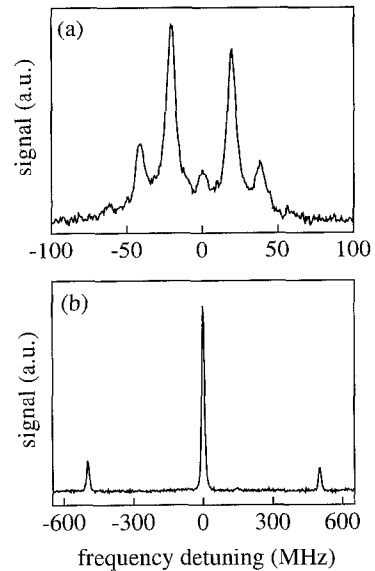

Fig. 4. Spectra of the laser output modulated at 20 MHz (a) and 500 MHz (b). The spectra are obtained by observing the transmission of a scanning Fabry-Pérot resonator (spectral resolution 10 MHz). We have used -13 dBm RF-power in (a) and 15 dBm in (b) respectively.

up to the microwave regime provides an economic and reliable method to serve the same needs [21]. We have, for example, performed laser cooling of a lithium (hyperfine structure 800 MHz) atomic beam [15,16,22] with a single grating-stabilized diode laser at 670 nm modulated by 800 MHz or excited ground state hyperfine coherences [23] in rubidium (hyperfine structure 3 GHz) at 780 nm using FM sidebands at 1.5 GHz (involving 70% of the total output power).

4. Tunable optical phase locked loop

Due to its high frequency stability our diode laser system is an ideal oscillator for optical phase locked loops (OPLL) [24]. In this section, we describe the performance of two diode laser systems synchronized by means of a heterodyne OPLL which locks the frequency difference of the lasers to a tunable radio-frequency source. The tunability of our OPLL offers a wide range of applications. It presents a superior alternative to the frequency modulation with acousto-optic modulators, since the OPLL has no influence on the intensity and optical quality of the laser beam. The

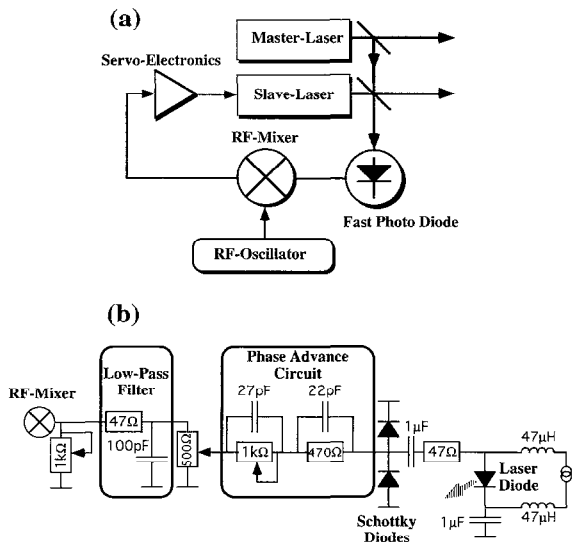

Fig. 5. (a) Schematics of the set-up for the optical phase locked loop (OPLL) between two independent lasers systems. The frequency of the master laser is stabilized to a Doppler-free resonance of the rubidium D2 line, using standard techniques. The frequency of the slave laser is stabilized by a heterodyne OPLL. (b) Electronic circuitry for the OPLL. The output signal from the RF-mixer is low-pass filtered (3 dB point at 34 MHz) to suppress the frequency of the local oscillator and its higher harmonics. A phase advance circuit then compensates for the delay with the error signal undergoes between the photodiode and the slave laser. The two Schottky diodes eliminate high frequency spikes that could damage the laser diode.

frequency range which is determined by the radio-frequency components can be set to any value between some ten MHz and several GHz.

The set-up of our OPLL is schematically shown in Fig. 5a. We employ a voltage tuned oscillator (VTO, Avantek VTO 9020) as a local oscillator (linewidth < 1 kHz, output power 10 dBm) which can be tuned between 200 MHz and 400 MHz by applying a DC voltage (0–15 V). A beat note between the master laser and the slave laser is recorded by an avalanche photodiode (Mitsubishi PD 1002) which has a bandwidth of 3 GHz. The output of the photodiode is amplified to a level of 10 dBm. The phase difference between the beat signal and the local oscillator is detected with an RF-mixer (Mini-Circuits MPD-21, 500 Ω impedance at DC-port). The output signal from the mixer is low-pass filtered (3 dB point at 34 MHz) to suppress the local oscillator frequency and its higher harmonics. A 500 Ω potentiometer enables gain control. The 1 k Ω potentiometer connected to the mixer output allows the impe-

dance of the circuitry to be adjusted to the required value of about 500 Ω . A phase advance circuit compensates for the phase delay experienced by the error signal on its path between the photodiode and the slave laser (see Fig. 5b) [25]. The output of this circuit is capacitively coupled to the injection current of the diode laser. This fast control loop facilitates adjustment over a bandwidth of almost 5 MHz. A second, low-frequency servo-loop is used to compensate for slow perturbations with higher amplitudes, e.g. of thermal and acoustic origin. The output of the mixer is integrated, amplified and fed to the PZT which controls the position of the laser diode grating. The beat signal between two phase locked laser diodes is shown in Fig. 6.

We have used the same technique described here also for higher radio-frequency offsets between the master and slave laser frequencies, e.g. 3 GHz. In this case, the beat note is firstly demodulated by means of a 2.8 GHz local oscillator in an appropriate RF-mixer (Mini-Circuits ZWL-1H) to obtain a 200 MHz signal which is then treated in the same fashion as described above. Operation of an OPLL at small offset frequencies down to 30 MHz (which is close to the desired bandwidth of several MHz) is also possible. In this case the low pass filter in Fig. 5b should be replaced by a third order Bessel filter with a cut-off frequency around 10 MHz, in order to increase the suppression of the local oscillator frequency of 30 MHz which otherwise may yield FM-sidebands.

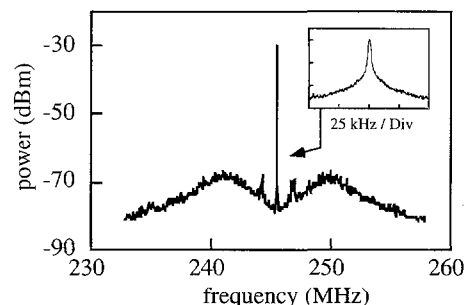

Fig. 6. Beat signal between the master laser and the slave laser with closed OPLL. A frequency span of 25 MHz was recorded with a resolution bandwidth of 1 kHz and a video filter bandwidth of 1 kHz. The increase in the noise level ± 5 MHz from the center shows the noise sidebands of the stabilization loop. The inset shows a frequency span of 100 kHz, recorded with a resolution bandwidth of 1 kHz and a video filter bandwidth of 30 Hz. The width of the beat signal is limited by the resolution of the spectrum analyzer.

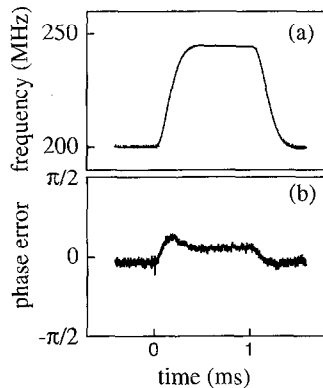

Fig. 7. Controlled frequency jump with closed OPLL. The upper diagram (a) shows the frequency scan carried out by the VTO. The lower diagram (b) shows the phase error of the OPLL at the same time.

Laser cooling experiments often make it necessary to change the frequency difference between two lasers rapidly and in a well controlled manner (e.g. for cooling atoms in a moving frame [26]). We can carry out frequency jumps of the slave laser relative to the master laser of 50 MHz in less than 200 μ s, while keeping the OPLL closed. For this purpose, we apply a rectangular voltage pulse smoothed by a third order Bessel filter to the VTO. The corresponding output frequency of the VTO is shown in Fig. 7a. The OPLL follows this fast frequency jump if we simultaneously apply the smoothed pulse to the injection current of the slave laser. With this technique, the OPLL can be kept closed and the phase error is only a small fraction of 2π during the frequency jump, as shown in Fig. 7b.

5. Conclusion

In summary, we have described a compact, economic set-up for stabilizing diode lasers by means of optical feedback from a diffraction grating which offers tunable narrow band radiation at low cost. The design of our laser system combines extreme simplicity with reliability and high performance thus making it feasible to operate a large number of lasers simultaneously. Our laser system can be operated with commercial laser diodes available at different wavelengths (e.g. 670 nm, 780 nm, 850 nm). We have demonstrated high tuning and scanning performances, modulation of RF-side-

bands up to the GHz range, and phase locking of two independent systems.

Acknowledgements

This work was partially supported by the Deutsche Forschungsgemeinschaft and by an ECC SCIENCE program cooperation, Contract No. SCICT 92-0816. We gratefully acknowledge the technical assistance by Frank Sander.

References

- [1] J. Camparo, *Contemp. Phys. Methods* 26 (1985) 443.
- [2] R. Lang and K. Kobayashi, *IEEE J. Quantum Electron.* QE-16 (1980) 347.
- [3] R. Dahmani, L. Hollberg and R. Drullinger, *Optics Lett.* 187 (1987) 876.
- [4] K. MacAdam, A. Steinbach and C. Wieman, *Am. J. Phys.* 60 (1992) 1098.
- [5] C. Wieman, L. Hollberg, *Rev. Sci. Instrum.* 62 (1991) 1.
- [6] A. Hemmerich, D. McIntyre, D. Schropp, D. Meschede and T.W. Hänsch, *Optics Comm.* 75 (1990) 118.
- [7] O. Nilsson, S. Saito and Y. Yamamoto, *Electron. Lett.* 17 (1981) 589.
- [8] S. Chu, *Scientific American* (February 1992); C. Cohen-Tannoudji and W. Phillips, *Physics Today* (October 1990), p. 33.
- [9] A. Hemmerich and T.W. Hänsch, *Phys. Rev. Lett.* 70 (1993) 410; A. Hemmerich, C. Zimmermann and T.W. Hänsch, *Phys. Rev. Lett.* 72 (1994) 625; M. Prentiss, *Science* 260 (1993) 1078; G. Collins, *Physics Today*, June (1993); B. Stein, *New Scientist*, January 29 (1994).
- [10] T. Esslinger, M. Weidemüller, A. Hemmerich and T.W. Hänsch, *Optics Lett.* 18 (1993) 450.
- [11] H. Telle, D. Meschede and T.W. Hänsch, *Optics Lett.* 15 (1990) 532.
- [12] W. König, *Frequenzmessung des 1S-2S Übergangs von atomarem Wasserstoff*, Dissertation, Universität Munich (1993), unpublished.
- [13] H. Li and H.R. Telle, *IEEE J. Quantum Electron.* 25 (1989) 257; P. Laurent, A. Clairon and Ch. Breant, *IEEE J. Quantum Electron.* 25 (1989) 1131; H. Li and N. Abraham, *Appl. Phys. Lett.* 53 (1988) 2257; R. Kazarinov and C. Henry, *IEEE J. Quantum Electron.* 23 (1987) 1401; C. Henry and R. Kazarinov, *IEEE J. Quantum Electron.* 22 (1986) 294.
- [14] M. Prevedelli, T. Freearge and T.W. Hänsch, Phase locking of grating tuned diode lasers, *Appl. Phys. B*, to be published.

- [15] P. McNicholl and H.J. Metcalf, *Appl. Optics* 24 (1985) 2757.
- [16] W. Ertmer, R. Blatt, J. Hall and M. Zhu, *Phys. Rev. Lett.* 54 (1985) 996.
- [17] T.W. Hänsch and A. Schawlow, *Optics Comm.* 13 (1975) 68; W. Phillips, J. Prodan and H. Metcalf, *J. Opt. Soc. Am. B* 2 (1985) 1752; R.N. Watts and C.E. Wieman, *Optics Lett.* 11 (1986) 291.
- [18] R. Drever, J. Hall, F. Kowalski, J. Hough, G. Ford, A. Munley and H. Ward, *Appl. Phys. B* 31 (1983) 97.
- [19] G. Bjorklund and M. Levenson, *Appl. Phys. B* 32 (1983) 145.
- [20] L. Hollberg, *Frequency Standards and Metrology*, A. de Marchi ed., Proc. 4th Symposium, Ancona September 5-9, Italy (1988).
- [21] C.J. Myatt, N.R. Newbury and C.E. Wieman, *Optics Lett.* 18 (1993) 649.
- [22] Z. Lin, K. Shimizu, M. Zhan, F. Shimizu and H. Takuma, *Jpn. J. Appl. Phys.* 30 (1991) L1324; C. Bradley, J. Story, J. Tollet, J. Chen, N. Ritchie and R. Hulet, *Optics Lett.* 17 (1992) 349; M. Weidemüller, C. Gabbanini, J. Hare, M. Gross and S. Haroche, *Optics Comm.* 101 (1993) 342.
- [23] G. Alzetta, A. Gozzini, L. Moi and G. Orriols, *Nuovo Cimento B* 56 (1976) 5; E. Arimondo and G. Orriols, *Nuovo Cimento Lett.* 17 (1976) 133.
- [24] H. Telle and H. Li, *Electron. Lett.* 26 (1990) 858; Telle, D. Meschede and T.W. Hänsch, *Optics Lett.* 15 (1990) 532; G. Santarelli, A. Clairon, S. Lea and G. Tino, *Optics Comm.* 104 (1994) 339.
- [25] S. Schwartz, J. Hall, K. Gibble and D. Weiss, *J. Opt. Soc. Am. B*, to be published.
- [26] M. Kasevich, K. Moler, E. Riis, E. Sunderman, D. Weiss and S. Chu, *Atomic Physics 12*, AIP Conf. Proc. 1990.